

# OPERATION & SAFETY MANUAL

SERIAL NO. \_\_\_\_\_

# PS-1030 PS-1430 PS-1930



To view machine specific information on your mobile device, scan the code to the left.

Decals with this code can also be found on the manual box and base of the machine.



## PRO SERIES

MOBILE  
ELEVATING  
WORK  
PLATFORMS

ANSI A92.20  
CSA B354.6:17  
EN-280:2013+A1:2015  
PS5.0-S | REV G

## This manual refers to serial number(s):

**PS-1030** PS10-50001 -

**PS-1430** PS14-50001 -

**PS-1930** PS19-50001 -

CE Units will have "CE-" in front of serial number (CE-PS1X-5XXXX)

**For older Serial Numbers refer to our website:**

[www.axcs.com/Manuals.htm](http://www.axcs.com/Manuals.htm)

## CE DECLARATION OF CONFORMITY

We hereby declare that the above mentioned machine has been assessed, tested and approved in accordance with the requirements of the Machinery Directive 2006/42/EEC using the document EC Community Legislation on Machinery and taking guidance from EN280:2013 + A1:2015.

Model Number: PS-1030, 1430, & 1930

Machine Type: Mobile Elevating Work Platform

Applicable Harmonised Standard: EN280:2013+A1:2015

Manufacturer:

Custom Equipment, LLC

2647 Hwy 175

Richfield, WI 53076, USA

Phone: [262-644-1300](tel:262-644-1300) / Fax: [262-644-1320](tel:262-644-1320)

[www.hybridlifts.com](http://www.hybridlifts.com)

Authorised Representative:

Collé Rental and Sales

Nusterweg 100

6136 KV Sittard

The Netherlands

Notified Body:

SGS North America Inc.

620 Old Peachtree Rd NW

Suite100

Suwanee, GA 30024

## General Information

2647 Hwy 175

Richfield, WI 53076

U.S.A.

 [+1-262-644-1300](tel:+1-262-644-1300)

 [+1-262-644-1320](tel:+1-262-644-1320)

 [www.axcs.com](http://www.axcs.com)

## Service Information

 [+1-262-297-5195](tel:+1-262-297-5195)

 [webservice@hybridlifts.com](mailto:webservice@hybridlifts.com)

## Parts Information

 [+1-262-297-5196](tel:+1-262-297-5196)

 [webparts@hybridlifts.com](mailto:webparts@hybridlifts.com)

### Register your Hy-Brid Lift at:

[www.axcs.com/RegisterOnline.htm](http://www.axcs.com/RegisterOnline.htm)

### Register to:

- Receive product updates and recalls
- Receive service bulletins, product and part recalls, and other important notifications
- Provide better records for service



# WARNING

REGISTERING YOUR MEWP WITH THE  
MANUFACTURER IS AN ANSI A92.20  
REQUIREMENT.

**Original instructions are written in English**

The purpose of this Operations and Safety manual is to provide users with the instructions and operating procedures essential to properly and safely operate the Hy-Brid Lift for its intended purpose, and to position personnel and their necessary tools and materials.

- The user/operator should not accept operating responsibility until the manual has been read and understood as well as having operated the lift under supervision of an experienced and qualified operator.
- Because the manufacturer has no direct control over machine application and operation, proper safety practices are the responsibility of the user and all operating personnel.



**DANGER**

**THE OPERATION AND SAFETY MANUAL MUST BE READ AND UNDERSTOOD PRIOR TO OPERATING THE MACHINE.**



**WARNING**

**ANY MODIFICATION ON THIS MACHINE WITHOUT THE EXPRESS WRITTEN CONSENT OF THE MANUFACTURER IS PROHIBITED.**

**FALL PROTECTION NOTICE**

The guardrail system around the perimeter of the platform is the fall protection system for self-propelled Mobile Elevating Work Platforms (MEWP) per the ANSI A92.20/CSA B354.6:17/EN-280:2013+A1:2015 Standards. It is prohibited to use an MEWP manufactured by Custom Equipment, LLC, with any portion—or all—of the guardrails removed. Lanyard anchorage points on this type of equipment are not required to conform to the applicable standard. However, if anchorage points for lanyard attachments are required by site authorities or other regulations, the anchorage points on all equipment manufactured by Custom Equipment, LLC are designed to be used for work positioning restraints of personnel only. Lanyard lengths are to be determined by operator/owner to restrict the operator to the confines within the guardrail system.

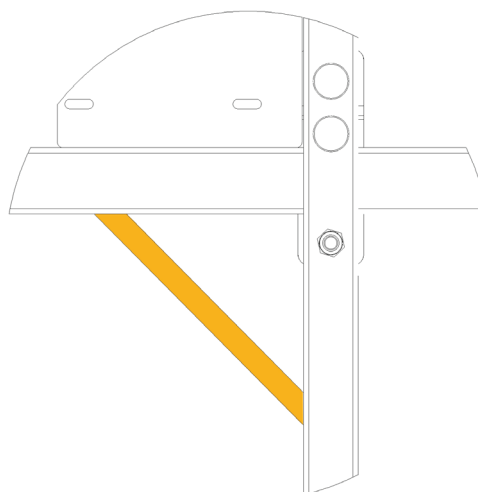

FIGURE 1: Lanyard Attachment



**WARNING**

**USE OF FALL ARREST SYSTEMS ATTACHED TO ANCHORAGE POINTS ON EQUIPMENT MAY CAUSE MACHINE TO TIP, RESULTING IN SERIOUS INJURY OR DEATH.**

# TABLE OF CONTENTS

<b>FORWARD</b> .....	<b>3</b>
<b>TABLE OF CONTENTS</b> .....	<b>4</b>
<b>SECTION 1 FAMILIARIZATION</b> .....	<b>6</b>
1.1   REQUIREMENT FOR CONFIRMATION OF MANUALS.....	6
1.2   PURPOSE AND FUNCTION OF CONTROLS.....	6
1.3   NON-OPERATING CHARACTERISTICS .....	6
1.4   OPERATING CHARACTERISTICS .....	7
<b>SECTION 2 SAFETY</b> .....	<b>8</b>
2.1   SAFETY SYMBOLS .....	8
2.2   GENERAL RULES AND PRECAUTIONS.....	8
2.3   SAFETY FEATURES.....	9
2.4   SAFETY INDICATORS & INTERLOCKS.....	9
2.5   SAFETY CONTROLS.....	10
2.6   MAINTENANCE LOCK.....	11
2.7   SAFETY GUIDELINES.....	12
<b>SECTION 3 PRODUCT DESCRIPTION</b> .....	<b>14</b>
3.1   GENERAL.....	14
<b>SECTION 4 DECALS</b> .....	<b>16</b>
4.1   PS-1030 DECAL LOCATIONS AND DESCRIPTION.....	16
4.2   PS-1430 DECAL LOCATIONS AND DESCRIPTION .....	18
4.3   PS-1930 DECAL LOCATIONS AND DESCRIPTION .....	20
4.4   DECAL SYMBOLS.....	22
<b>SECTION 5 TRANSPORT, HANDLING &amp; STORAGE</b> .....	<b>26</b>
5.1   PRELIMINARY UNPACKING INSTRUCTIONS AND DEALER INSPECTION .....	26
5.2   STORAGE.....	26
5.3   PREPARATION FOR TRANSIT .....	26
5.4   LIFTING AND TIE-DOWN POINTS.....	27
5.5   FORK LIFT POCKETS .....	28
5.6   CENTER OF GRAVITY.....	28
<b>SECTION 6 OPERATION</b> .....	<b>30</b>
6.1   BEFORE YOU OPERATE .....	30
6.2   BASE CONTROLS.....	30
6.3   BRAKE RELEASE .....	30
6.4   PLATFORM CONTROLS.....	31
6.5   INFORMATION DISPLAY FEATURE .....	32
6.6   INFORMATION DISPLAY DIAGNOSTICS.....	32
6.7   STARTUP/SHUTDOWN .....	33
6.8   ERROR ALARMS.....	34
6.9   DRIVING AND STEERING.....	35
6.10   ELEVATING AND LOWERING.....	36
6.11   EXTENDING THE PLATFORM.....	36
6.12   POWER TO PLATFORM .....	37
6.13   DAILY MAINTENANCE.....	38
6.14   CHARGING THE BATTERY.....	38
6.15   BATTERY DISPLAYS .....	39

**SECTION 7 PRE-START INSPECTION.....40**  
 7.1 | PRE-START INSPECTION CHECKLIST .....40  
 7.2 | LEAKGUARD™ FLUID CONTAINMENT SYSTEM.....40  
**NOTES.....42**  
**NOTES.....43**

**INDEX OF FIGURES**

FIGURE 1: Lanyard Attachment ..... 3  
 FIGURE 2: Manual Storage Location ..... 6  
 FIGURE 3: Pothole Guard ..... 9  
 FIGURE 4: Auxiliary Lowering.....10  
 FIGURE 5: Lowering Instructions .....10  
 FIGURE 6: Maintenance Lock Storage .....11  
 FIGURE 7: Maintenance Lock In Use .....11  
 FIGURE 8: PS-1030 Decal Locations.....16  
 FIGURE 9: PS-1430 Decal Locations.....18  
 FIGURE 10: PS-1930 Decal Locations.....20  
 FIGURE 11: Tie-Down Points, Rear .....27  
 FIGURE 12: Tie-Down Points, Front.....27  
 FIGURE 13: Fork Pockets.....28  
 FIGURE 14: Center of Gravity.....28  
 FIGURE 15: Base Controls.....30  
 FIGURE 16: Platform Controls Style 1 .....31  
 FIGURE 17: Platform Controls Style 2 .....31  
 FIGURE 18: Battery Life Display .....32  
 FIGURE 19: Master Power and Key Switch.....33  
 FIGURE 20: Slide Lock Handle.....36  
 FIGURE 22: Power to Platform Outlet.....37  
 FIGURE 21: Power to Platform Plug .....37  
 FIGURE 23: Charger Cord Location .....38  
 FIGURE 24: Battery Charger LED Display .....39  
 FIGURE 25: Battery Charge Display: Delta-Q RQ 350.....39  
 FIGURE 26: LeakGuard™ Location.....40

**REVISION LOG**

REV A .....January 2020  
 REV B .....January 2020  
 REV C..... February 2020  
 REV D..... February 2020  
 REV E .....November 2020  
 REV F..... January 2022  
 REV G..... March 2023

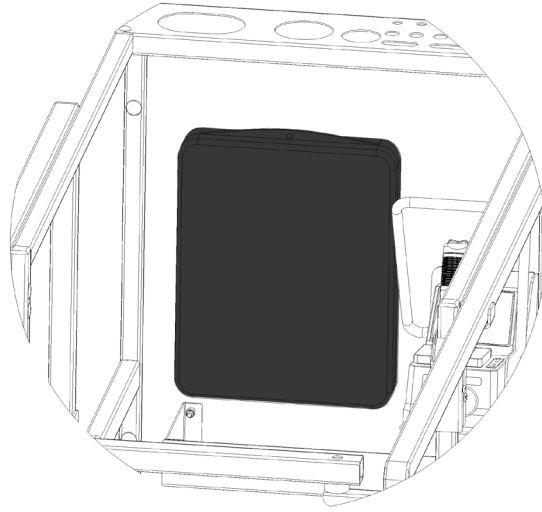

FIGURE 2: Manual Storage Location

**1.1 | REQUIREMENT FOR CONFIRMATION OF MANUALS**

Page	Section
33	6.7   START-UP/SHUTDOWN

**1.2 | PURPOSE AND FUNCTION OF CONTROLS**

Page	Section
10	2.5   SAFETY CONTROLS
30	6.1   BEFORE YOU OPERATE
35	6.9   DRIVING AND STEERING
36	6.10   ELEVATING AND LOWERING

**1.3 | NON-OPERATING CHARACTERISTICS**

FEATURES	
Page	Section
9	2.3   SAFETY FEATURES
12	2.7   SAFETY GUIDELINES
14 - 15	3.1   GENERAL
16 - 24	4   DECALS
27	5.4   LIFTING AND TIE DOWN POINTS
28	5.5   FORK LIFT POCKETS
33	6.7   STARTUP/SHUTDOWN
35	6.9   DRIVING AND STEERING
36	6.11   EXTENDING THE PLATFORM
37	6.12   POWER TO PLATFORM

<b>LIMITATIONS</b>	
<b>Page</b>	<b>Section</b>
9	2.4   SAFETY INDICATOR AND INTERLOCKS
12	2.7   SAFETY GUIDELINES
14 - 15	3.1   GENERAL
22 - 24	4.5   DECAL SYMBOLS
26	5.2   STORAGE
26	5.3   PREPARATION FOR TRANSIT
28	5.5   FORK LIFT POCKETS
33	6.7   STARTUP/SHUTDOWN
34	6.8   ERROR ALARMS
38	6.14   CHARGING THE BATTERY

<b>DEVICES</b>	
<b>Page</b>	<b>Section</b>
9	2.4   SAFETY INDICATOR AND INTERLOCKS
10	2.5   SAFETY CONTROLS
11	2.6   MAINTENANCE LOCK
14 - 15	3.1   GENERAL
22 - 24	4.4   DECAL SYMBOLS
26	5.3   PREPARATION FOR TRANSIT
30	6.1   BEFORE YOU OPERATE
38	6.14   CHARGING THE BATTERY

## 1.4 | OPERATING CHARACTERISTICS

<b>Page</b>	<b>Section</b>
9	2.4   SAFETY INDICATORS AND INTERLOCKS
10	2.5   SAFETY CONTROLS
11	2.6   MAINTENANCE LOCK
14 - 15	3.1   GENERAL
26	5.3   PREPARATION FOR TRANSIT
32	6.5   INFORMATION DISPLAY FEATURE
38	6.14   CHARGING THE BATTERY

2.1 | SAFETY SYMBOLS



**FAILURE TO FOLLOW THIS WARNING WILL CAUSE DEATH OR PERSONAL INJURY.**

"DANGER" indicates an imminently hazardous situation, which, if not avoided, will result in death or serious injury.



**FAILURE TO FOLLOW THIS WARNING MAY CAUSE DEATH OR PERSONAL INJURY.**

"WARNING" indicates a potentially hazardous situation, which, if not avoided, could result in death or serious injury.



**FAILURE TO FOLLOW THIS WARNING MAY CAUSE INJURY OR DAMAGE TO EQUIPMENT.**

"CAUTION" indicates a potentially hazardous situation which, if not avoided, could result in minor or moderate injury or damage to equipment.

2.2 | GENERAL RULES AND PRECAUTIONS

An operator of any type of work platform is subject to certain hazards that cannot be protected by mechanical means. It is therefore essential that operators be competent, careful, physically and mentally fit, and thoroughly trained in safe operation of this machine.

Although Custom Equipment, LLC conforms to specified ANSI, OSHA, CSA, and CE standards, it is the responsibility of the owner to instruct operators with the safety requirements made not only by Custom Equipment, LLC, but by the various safety boards in your area, as well as additional requirements set forth by ANSI, OSHA, CSA, or CE. If you come across a situation that you think might be unsafe, stop the platform and request further information from qualified sources before proceeding.



**NEVER REACH BETWEEN SCISSORS LINKS OR PROP UP PLATFORM**



**STEERING BRACKETS EXTENDING BEYOND THE SIDES OF THE BASE MAY OCCUR IN TIGHT TURNING SITUATIONS**

Potential damage to walls, etc., may occur in tight turning situations due to the steering brackets extending beyond the sides of the base.

## 2.3 | SAFETY FEATURES

### Puncture-Proof Wheels

### Guardrails

43.5 in (110.5 cm) height with 6 in (15 cm) toe guards and a 4 in (10 cm) gate toe guard.

### Non-Slip Deck

### Entrance Gate

### Automatic Parking Brake

### Free Descent Protection

A holding valve is installed in the manifold block to prevent the platform from descending in case of a ruptured hydraulic hose. The platform is hydraulically locked until hose has been replaced.

### Decals

Danger, Caution, and Warning decals are displayed at various locations on this unit.

### Key Switch Security

To prevent unauthorized use, a key switch is required for operation.

## 2.4 | SAFETY INDICATORS & INTERLOCKS

### Tilt Alarm

An audible alarm sounds when the machine is tilted more than 2° longitudinally or 1.5° laterally. Elevating and driving functions are inhibited. Lower the platform and move to a level surface.

### Descent/Motion Alarm

An audible alarm sounds when the machine is lowering. Some models also sound an alarm when the machine is elevating or driving.

### Slope Alarm

An audible alarm sounds when the stowed machine is on a ramp.

### Overload/Warning Alarm

An LED on the base controls will activate when the load for the platform approaches maximum rating. An audible alarm will sound once the rated load has been exceeded. See the "Operation" section of this manual for more detail.

### Pothole Protection

Pothole guards are required to be in place when the lift is in the elevated position. If the guards are blocked or not functioning properly, elevating functions will be inhibited. Lower the machine and do not operate until the problem is repaired or the obstruction is removed.

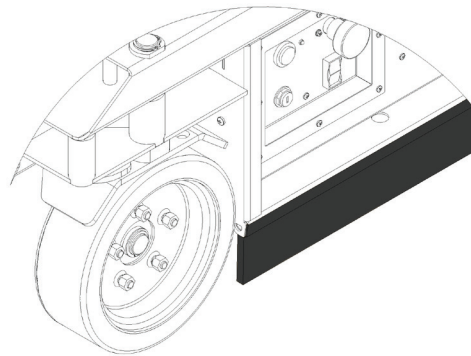

FIGURE 3: Pothole Guard

2.5 | **SAFETY CONTROLS**

**Auxiliary Lowering: Descent - Manual Override**

For manually lowering the scissors in the case of power failure, a manual valve on the pump is provided. To lower the scissors, pull the cable located at the rear of the machine.

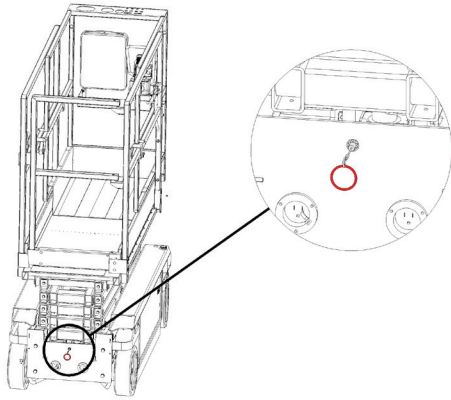

FIGURE 4: Auxiliary Lowering

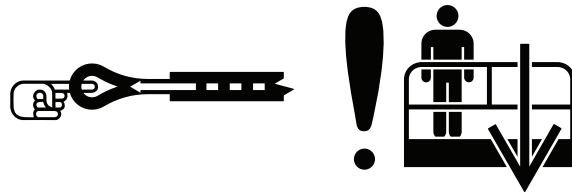

FIGURE 5: Lowering Instructions

**! WARNING**

IF PLATFORM SHOULD FAIL TO LOWER, DO NOT ATTEMPT TO CLIMB DOWN THE SCISSOR ASSEMBLY. SERIOUS INJURY MAY RESULT. HAVE AN EXPERIENCED OPERATOR USE THE EMERGENCY LOWERING PROCEDURE TO SAFELY LOWER THE PLATFORM.

**! WARNING**

BEFORE LOWERING PLATFORM, RETRACT THE DECK EXTENSION.

**Emergency Stop**

This lift is equipped with two emergency stops, one at the platform control and one at the base control, that when activated, will render the unit inoperable until reset. To reset, pull the emergency stop out.

**! WARNING**

PUSHING THE EMERGENCY STOP WILL APPLY BRAKES IMMEDIATELY. THIS MAY CAUSE UNEXPECTED PLATFORM MOVEMENT AS THE MACHINE COMES TO A SUDDEN STOP. BRACE YOURSELF AND SECURE OBJECTS ON THE PLATFORM DURING OPERATION OF THE MACHINE.

## 2.6 | MAINTENANCE LOCK

The maintenance locks must be placed into position whenever the machine is being serviced in the raised or partially raised position. Serious injury and/or death could result if the maintenance locks are not used properly.

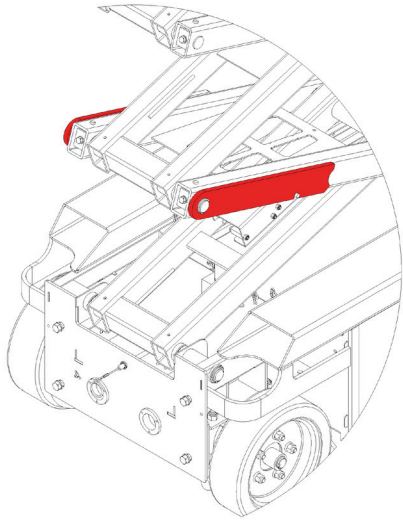

FIGURE 6: Maintenance Lock Storage

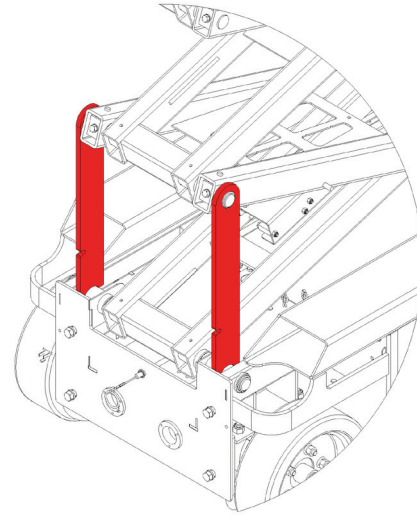

FIGURE 7: Maintenance Lock In Use

### 2.7 | SAFETY GUIDELINES

#### Only qualified operators may operate this unit

- All operators must read and understand the Operation and Safety Manual. They must understand all decals and warning labels on unit.
- Do not work on platform if your physical condition is such that you feel dizzy or unsteady in any way.
- Do not neglect/misuse machine. Report any misuse of equipment to proper personnel.
- Prevent unauthorized use; when unit is not in use, remove key.
- It is recommended all personnel on unit wear approved personal protective equipment (PPE), i.e. head gear.

#### Use machine only for purposes for which it was intended

- Lift should never be used as a crane.
- Do not exceed the load capabilities of the platform.
- Distribute load evenly over platform floor area.
- Never use unit as electrical grounds for arc welding.
- Do not override any hydraulic, mechanical, or electrical safety devices.

#### Check job site for unsafe working conditions

- Watch out for others. Keep others clear of operating platform. Never allow others to pass under a raised platform or position the platform over someone.
- Avoid contact with fixed objects (walls, buildings, or other machinery, etc) or moving vehicles (automobiles, cranes, etc).
- Follow any applicable national traffic regulations.
- Use indoors only when in indoor mode. Use outdoor mode when using MEWP outside. Lift is not designed for use outdoors during electrical storms.
- Unit must be on hard level surface before elevating. Do not operate on incline or uneven surface.
- You must maintain a clearance between any part of the machine, or its load, and any electrical line or apparatus. Follow local power line clearance regulations.



**DO NOT OPERATE MACHINE NEAR POWER LINES.  
THE PLATFORM AND ENCLOSURES ARE NOT  
INSULATED.**

#### Equipment is only as safe as the operator

- Do not use ladders or scaffolding on the platform to obtain greater height.
- Do not enter or exit platform while machine is in motion.
- Never mount or dismount a raised platform.
- Make sure entry gate is secured before operating machine from the platform.
- Never belt or tie off to an adjacent structure.
- Secure tools and materials.
- Personnel must maintain a firm footing on the platform floor and work only within the platform area.
- It is recommended to avoid sudden braking or steering. Go slowly and leave more maneuvering room during cold weather operation.

#### Before operation, ensure that the machine is properly serviced

- Do not use machine if it is not working properly.
- Make sure platform rails and pins are secured.
- Operator shall use the maintenance lock when performing all types of maintenance procedures.
- Do not smoke while charging the battery.

---

THIS PAGE WAS INTENTIONALLY LEFT BLANK

## SECTION 3 **PRODUCT DESCRIPTION**

### 3.1 | GENERAL

Custom Equipment's Hy-Brid Lifts are mobile elevating work platforms designed to be safe and reliable. The purpose of the machine is to elevate personnel, along with their necessary tools and materials to overhead work locations.

Manufacturer approval is required for any use other than the intended use.

Before operation, the operator must read and understand the manufacturer's operating instructions and user's safety rules, or have them explained, understand all labels, warnings, and instructions displayed on the work platform or have them explained, ensure that all occupant of the work platform wear appropriate protective equipment for the conditions, including the environment in which the work platform will be operated.

The operator must inspect the workplace for environmental hazards such as, but not limited to drop-offs, holes, slopes, debris, floor or overhead obstructions, surface, wind and weather conditions, or presence of unauthorized persons. Vibration does not create significant hazards on this machine.

<b>SPECIFICATIONS</b>	<b>PS-1030</b>		<b>PS-1430</b>		<b>PS-1930</b>	
Working Height (1 Person Indoor)	<b>16.2 ft</b>	4.94 m	<b>20.3 ft</b>	6.19 m	<b>24.6 ft</b>	7.4 m
Working Height (2 Person Indoor/1 Person Outdoor)	<b>16.2 ft</b>	4.94 m	<b>16.5 ft</b>	5.03 m	<b>17.6 ft</b>	5.36 m
Platform Height (1 Person Indoor)	<b>10.2 ft</b>	3.11 m	<b>14.3 ft</b>	4.36 m	<b>18.4 ft</b>	5.6 m
Platform Height (2 Person Indoor/1 Person Outdoor)	<b>10.2 ft</b>	3.11 m	<b>10.5 ft</b>	3.2 m	<b>11.6 ft</b>	3.54 m
Stowed Height	<b>68.3 in</b>	173.5 cm	<b>71.3 in</b>	181.1 cm	<b>74.3 in</b>	188.7 cm
Platform Height Minimum	<b>25 in</b>	63.5 cm	<b>28 in</b>	71.1 cm	<b>31 in</b>	78.7 cm
Ground Clearance Lowered			<b>3.0 in</b>	7.6 cm		
Ground Clearance Elevated			<b>0.3 in</b>	0.8 cm		
Overall Width			<b>30 in</b>	76.2 cm		
Overall Length w/Step			<b>69.5 in</b>	176.5 cm		
Platform Length & Width			<b>21.8 in x 57.8 in</b>	55.4 cm x 146.8 cm		
Slide-Out Extension Deck Length			<b>30 in</b>	76.2 cm		
Guard Rail Height			<b>43.5 in</b>	110.5 cm		
Step Height			<b>19.5 in</b>	49.5 cm		
Wheel Base			<b>51.0 in</b>	129.5 cm		
Wheel Track			<b>23.6 in</b>	59.9 cm		
Inside Turn Radius			<b>8.0 in</b>	20.3 cm		
Outside Turn Radius			<b>62.7 in</b>	159.3 cm		
Tire Size (Solid, Non-Marking) - Front / Rear			<b>12 in / 12 in</b>	30.5 cm / 30.5 cm		

<b>SPECIFICATIONS</b>	<b>PS-1030</b>		<b>PS-1430</b>		<b>PS-1930</b>	
<b>RATED LOAD</b>						
Lift Capacity (Evenly Distributed)	800 lbs	2 Persons indoor 1 Person outdoor	700 lbs	2 Persons indoor 1 Person outdoor	650 lbs	2 Persons indoor 1 Person outdoor
	363 kg		318 kg		295 kg	
Slide-Out Extension Deck Capacity	250 lbs 113 kg 1 Person					
Horizontal/Manual Force	45 lbs 200 N					
<b>FLOOR LOADING</b>						
Machine Weight (Unloaded) (Approx.)	1500 lbs	680 kg	1780 lbs	807 kg	1985 lbs	900 kg
Minimum Wheel Load - Contact Pressure	82.2 psi	0.57 MPa	97.5 psi	0.67 MPa	107.0 psi	0.74 MPa
Maximum Wheel Load - Contact Pressure	112.0 psi	0.77 MPa	120.7 psi	0.83 MPa	126.7 psi	0.87 MPa
Minimum Machine Loading - Floor Loading Pressure	112.5 psf	5.4 kPa	133.5 psf	6.4 kPa	146.4 psf	7.0 kPa
Maximum Machine Loading - Floor Loading Pressure	172.5 psf	8.3 kPa	186.0 psf	8.9 kPa	195.2 psf	9.3 kPa
<b>ENVIRONMENTAL LIMITATIONS</b>						
Wind (Indoor)	No Wind					
Wind (Outdoor)	0.0145 psi 100 N/m <sup>2</sup>		28 mph 12.5 m/s			
Rated Slope	Level Surface					
Tilt Sensor Activated	2.0° Longitudinally / 1.5° Laterally					
Grade-ability (Stowed Position)	30% (16.7°) Unloaded					
Temperature	-4°F to 104°F -20° C to -40° C					
Vibration	8.2 ft/s <sup>2</sup> max 2.5 m/s <sup>2</sup> max					
Sound - Normal Use, Alarms	86 dB Normal Use					
<b>POWER SYSTEMS - DRIVE SYSTEM (Proportional Electric)</b>						
Drive Speed (Platform Elevated)	0.7 mph	0.3 m/s	0.7 mph	0.3 m/s	0.6 mph	0.3 m/s
Drive Speed (Platform Lowered)	2.4 mph 1.1 m/s					
Lift Speed (Up/Down)	28/28 sec					
Hydraulic Pressure (Max)	1750 psi 12.07 MPa					
Hydraulic Fluid Capacity	1.3 gal 4.62 L					
Power System - Voltage	24V DC					
Batteries - Deep Cycle Marine	(2) 12V Group 27					

4.1 | PS-1030 DECAL LOCATIONS AND DESCRIPTION

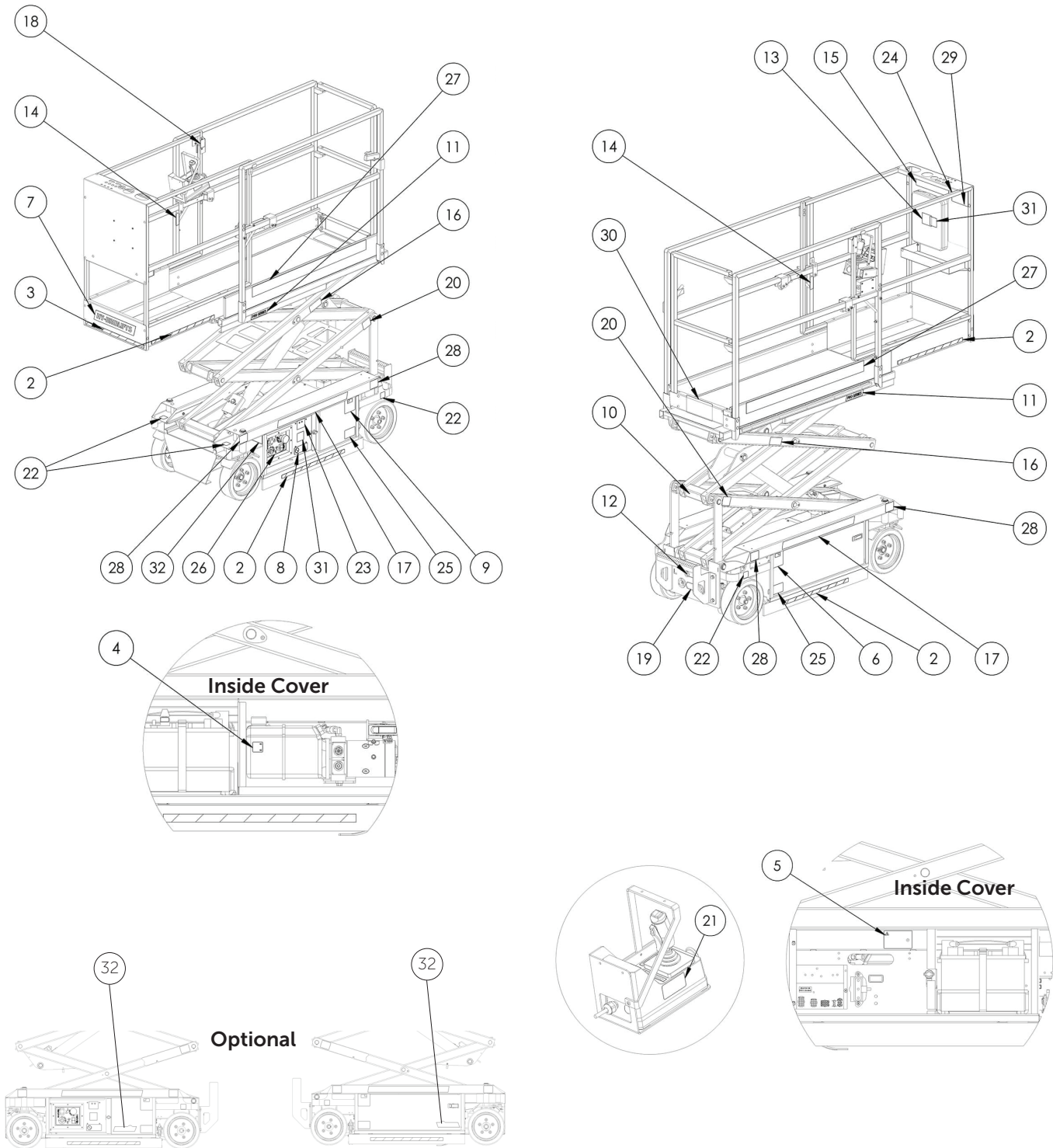

FIGURE 8: PS-1030 Decal Locations

ITEM NO.	PART NO.	SUF	REV	DECAL MEANING OR DESIGNATION	QTY
1	112-21-520	-50-K	B	DECALS,PS-1030 S5	1
2	DE717-61		A	DECAL,SAFETY STRIPE (24.00)	4
3	DE717-63		A	DECAL,SAFETY STRIPE (22.25)	1
4	DE1008		A	DECAL,HYDR FLUID	1
5	DE1022		A	DECAL,BATT/CHR COMPATABILITY	1
6	DE1031		A	DECAL,MADE IN USA MIRROR	1
7	DE1207		A	DECAL,HY-BRID LIFTS	1
8	DE1208		A	DECAL,BRAKE RELEASE/NO TOW	1
9	DE1221		A	DECAL,MADE IN USA	1
10	DE1230		A	DECAL,PROP 65	1
11	DE1236		A	DECAL,SERIES PS	2
12	DE1243		A	DECAL,E-DOWN CABLE	1
13	DE1246		A	DECAL,MANUAL BOX	1
14	DE1248		A	DECAL,LANYARD ATTACHMENT	2
15	DE1249		A	DECAL,ANNUAL INSPECTION	1
16	DE1250		A	DECAL,SCISSOR CRUSH HAZARD	2
17	DE1252		A	DECAL,WEBSITE	2
18	DE1259		A	DECAL,SLIDEOUT	1
19	DE1265		A	DECAL,CHARGER CORD/PTP	1
20	DE1266		A	DECAL,MAINT LOCK ARM	2
21	DE1276		A	DECAL,PS-COMPLIANCE	1
22	DE1278		A	DECAL,TIEDOWN	4
23	DE1279		A	DECAL,BATTERY CHARGER	1
24	DE1282		A	DECAL,PH CRUSH HAZARD	2
25	DE1032		A	DECAL,BASE LWR CTL PS	1
26	DE1213		A	DECAL,MODEL PS-1030	2
27	DE1264		A	DECAL,PS-1030 WHEEL LOAD	4
28	DE1267		B	DECAL,PS-1030 FRONT PANEL	1
29	DE1268		B	DECAL,PS-1030 CAPACITIES	1
30	DE1316		A	DECAL,QR PS SERIES 5	2
31	DE7035/ DE7040		A	DECAL,SERIAL NO PS-1030	1
32	DE1283		A	DECAL,LEAKGUARD™ (OPTIONAL)	2



ITEM NO.	PART NO.	SUF	REV	DECAL MEANING OR DESIGNATION	QTY
1	112-21-520	-53-K	B	DECALS,PS-1430 S5	1
2	DE717-61		A	DECAL,SAFETY STRIPE (24.00)	4
3	DE717-63		A	DECAL,SAFETY STRIPE (22.25)	1
4	DE1008		A	DECAL,HYDR FLUID	1
5	DE1022		A	DECAL,BATT/CHR COMPATABILITY	1
6	DE1031		A	DECAL,MADE IN USA MIRROR	1
7	DE1207		A	DECAL,HY-BRID LIFTS	1
8	DE1208		A	DECAL,BRAKE RELEASE/NO TOW	1
9	DE1221		A	DECAL,MADE IN USA	1
10	DE1230		A	DECAL,PROP 65	1
11	DE1236		A	DECAL,SERIES PS	2
12	DE1243		A	DECAL,E-DOWN CABLE	1
13	DE1246		A	DECAL,MANUAL BOX	1
14	DE1248		A	DECAL,LANYARD ATTACHMENT	2
15	DE1249		A	DECAL,ANNUAL INSPECTION	1
16	DE1250		A	DECAL,SCISSOR CRUSH HAZARD	2
17	DE1252		A	DECAL,WEBSITE	2
18	DE1259		A	DECAL,SLIDEOUT	1
19	DE1265		A	DECAL,CHARGER CORD/PTP	1
20	DE1266		A	DECAL,MAINT LOCK ARM	2
21	DE1276		A	DECAL,PS-COMPLIANCE	1
22	DE1278		A	DECAL,TIEDOWN	4
23	DE1279		A	DECAL,BATTERY CHARGER	1
24	DE1282		A	DECAL,PH CRUSH HAZARD	2
25	DE1032		A	DECAL,BASE LWR CTL PS	1
26	DE1214		A	DECAL,MODEL PS-1430	2
27	DE1270		A	DECAL,PS-1430 WHEEL LOAD	4
28	DE1271		B	DECAL,PS-1430 FRONT PANEL	1
29	DE1272		B	DECAL,PS-1430 CAPACITIES	1
30	DE1316		A	DECAL,QR PS SERIES 5	2
31	DE7034/ DE7039		A	DECAL,SERIAL NO PS-1430	1
32	DE1283		A	DECAL,LEAKGUARD™ (OPTIONAL)	2

4.3 | PS-1930 DECAL LOCATIONS AND DESCRIPTION

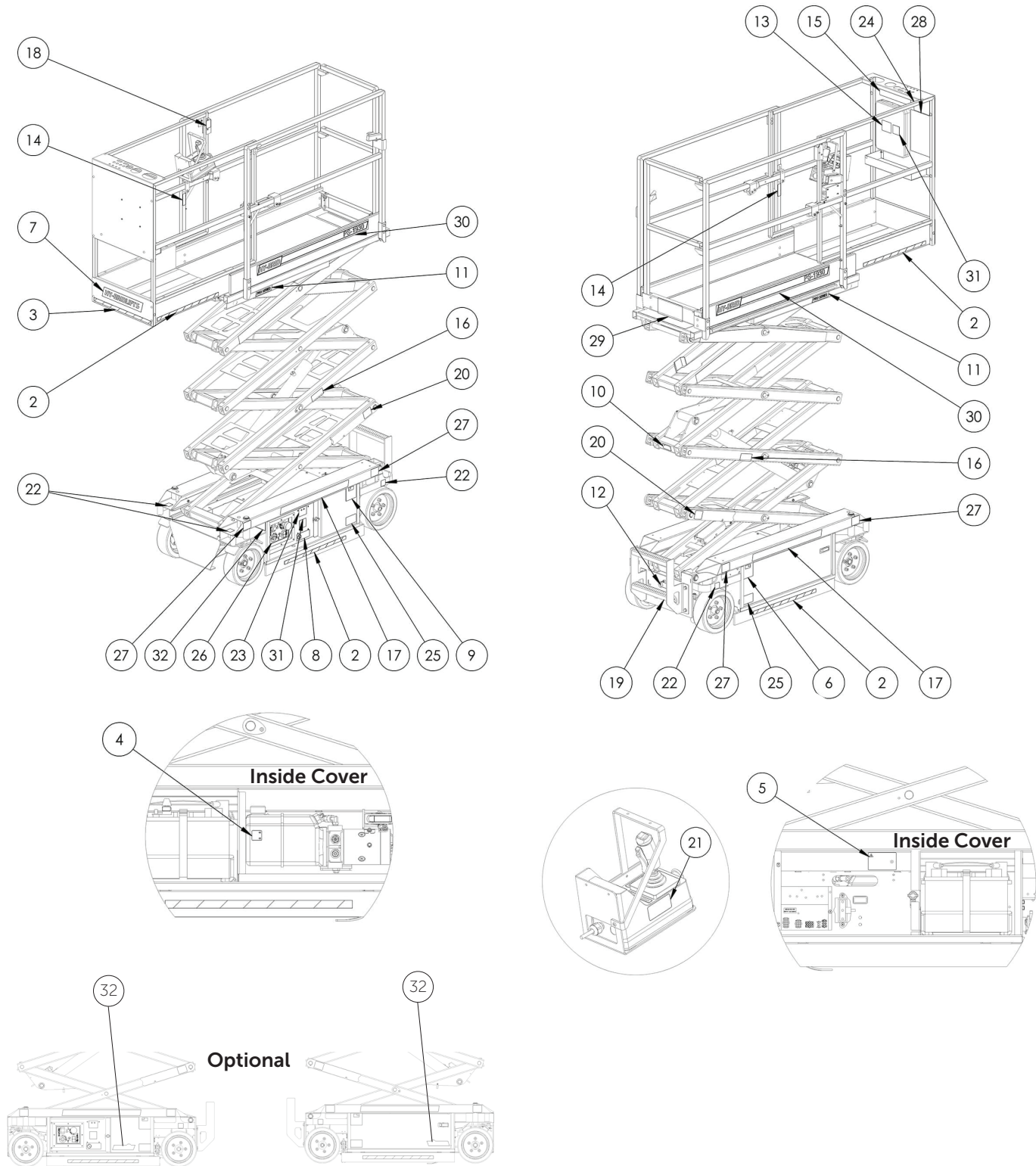

FIGURE 10: PS-1930 Decal Locations

ITEM NO.	PART NO.	SUF	REV	DECAL MEANING OR DESIGNATION	QTY
1	112-21-520	-56-K	B	DECALS,PS-1930 S5	1
2	DE717-61		A	DECAL,SAFETY STRIPE (24.00)	4
3	DE717-63		A	DECAL,SAFETY STRIPE (22.25)	1
4	DE1008		A	DECAL,HYDR FLUID	1
5	DE1022		A	DECAL,BATT/CHR COMPATABILITY	1
6	DE1031		A	DECAL,MADE IN USA MIRROR	1
7	DE1207		A	DECAL,HY-BRID LIFTS	1
8	DE1208		A	DECAL,BRAKE RELEASE/NO TOW	1
9	DE1221		A	DECAL,MADE IN USA	1
10	DE1230		A	DECAL,PROP 65	1
11	DE1236		A	DECAL,SERIES PS	2
12	DE1243		A	DECAL,E-DOWN CABLE	1
13	DE1246		A	DECAL,MANUAL BOX	1
14	DE1248		A	DECAL,LANYARD ATTACHMENT	2
15	DE1249		A	DECAL,ANNUAL INSPECTION	1
16	DE1250		A	DECAL,SCISSOR CRUSH HAZARD	2
17	DE1252		A	DECAL,WEBSITE	2
18	DE1259		A	DECAL,SLIDEOUT	1
19	DE1265		A	DECAL,CHARGER CORD/PTP	1
20	DE1266		A	DECAL,MAINT LOCK ARM	2
21	DE1276		A	DECAL,PS-COMPLIANCE	1
22	DE1278		A	DECAL,TIEDOWN	4
23	DE1279		A	DECAL,BATTERY CHARGER	1
24	DE1282		A	DECAL,PH CRUSH HAZARD	2
25	DE1032		A	DECAL,BASE LWR CTL PS	1
26	DE1273		A	DECAL,PS-1930 WHEEL LOAD	4
27	DE1274		B	DECAL,PS-1930 FRONT PANEL	1
28	DE1275		B	DECAL,PS-1930 CAPACITIES	1
29	DE1277		A	DECAL,MODEL PS-1930	2
30	DE1316		A	DECAL,QR PS SERIES 5	2
31	DE7033/ DE7038		A	DECAL,SERIAL NO PS-1930	1
32	DE1283		A	DECAL,LEAKGUARD™ (OPTIONAL)	2

4.4 | **DECAL SYMBOLS**



- No unauthorized use
- Do not operate this machine unless you have been trained in safe operation.
- Training includes complete knowledge of the safety and operating instructions contained in the manufacturer’s manual, your employer’s work rules, and applicable government regulations.
- An untrained operator subjects himself and others to death or serious injury.

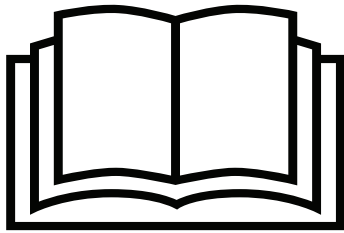

- Read and understand all dangers and warnings in the operator’s manual before operating this machine.
- Improper use of this machine could cause death or serious injury.
- Inspect machine and make sure that it is operating properly, that all name plate and hazard signs are in place and legible, and that the machine is in accordance with the manufacturer’s maintenance requirements contained in the operating and maintenance requirements contained in the operation and maintenance manual and the daily safety checklist.



- Crushing hazard
- Do not enter the space beneath the work platform or scissor structure unless the maintenance lock is in place.

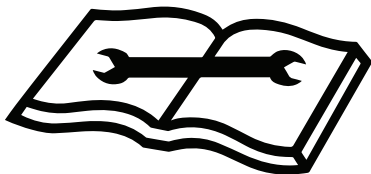

- Refer to Maintenance Manual
- Only qualified service personnel may service the machine. Failure to comply with listed safety precautions may result in machine damage, personnel injury, or death.
- Replace designated items with manufacturer’s specified equipment only. Failure to use these items may cause instability of platform.



- Batteries produce explosive gas. Only charge batteries in a well-ventilated area.
- Do not expose to sparks or flames.
- Do not smoke while charging battery.



- Wheel Load

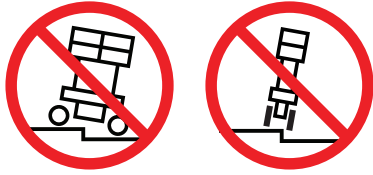

- Tip hazard
- Do not elevate platform on an incline or step.



- Tip hazard
- Do not elevate platform on a slope.



- Tip hazard
- Do not elevate platform on uneven or soft surfaces.

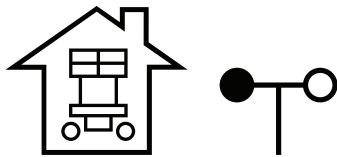

- Indoor use only: No Wind Load

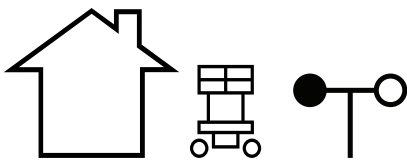

- Outdoor use: Max wind speed 28 mph.



- Platform with Extension

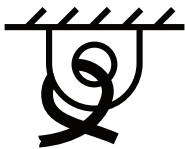

- Tie-down Location

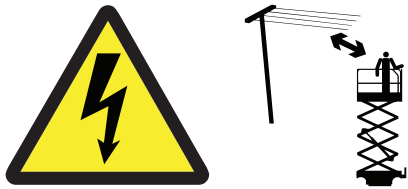

- Electrocution hazard
- This machine is not insulated.
- Maintain safe clearance from electrical lines and apparatus. You must allow for machine sway, rock or sag and electrical lines swaying.
- This machine does not provide protection from contact with or proximity to an electrically charged conductor.
- You must maintain a clearance between any part of this machine or its load and any electrical apparatus. Follow local power line regulations.
- Death or serious injury will result from contact or inadequate clearance.

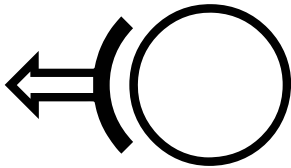

- Brake release

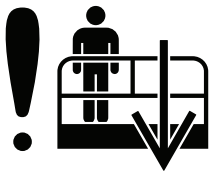

- Manual lowering override

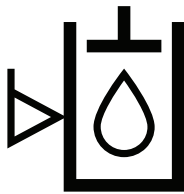

- Hydraulic oil level



- Lanyard anchorage point location: Capacity 1 Person
- Lanyard anchorage points are for work positioning restraints only, not for fall protection.
- Use of fall arrest systems attached to anchorage points on mobile equipment may cause machine to tip, resulting in serious injury or death.



- Tools and Materials

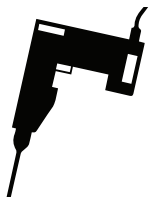

- Power to the Platform

---

THIS PAGE WAS INTENTIONALLY LEFT BLANK

### **5.1 | PRELIMINARY UNPACKING INSTRUCTIONS AND DEALER INSPECTION**

Maintenance locks must be engaged prior to inspecting or servicing the unit when the platform is elevated. Inspect machine for any possible damage during shipment; perform pre-delivery inspection. See checklist in the Maintenance Manual. Reset emergency stop switches, if necessary.

### **5.2 | STORAGE**

After periods of storage or exposure to extremes of ambient conditions (heat, cold, moisture, dust etc.) inspect the machine. Refer to the Pre-Delivery/Frequent Inspection Checklist of the Maintenance Manual.

### **5.3 | PREPARATION FOR TRANSIT**

- Lower the work platform to the down position.
- Bring the platform slide-out extension into the retracted position and lock in place.
- Turn the key switch to off position.
- Check the entire machine for loose or unsecured items.
- Remove any loose items from machine.
- Do not attempt to push or tow unit with the brakes applied. Severe gear damage will occur.
- Towing is not recommended.

**5.4 | LIFTING AND TIE-DOWN POINTS**

Tie-down points are provided for securing the machine on a trailer or truck bed for transport between places of use. The rear corners may also be used as lift points.

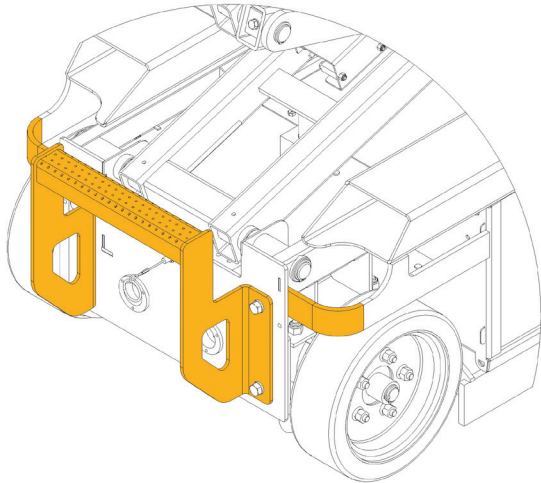

FIGURE 11: Tie-Down Points, Rear

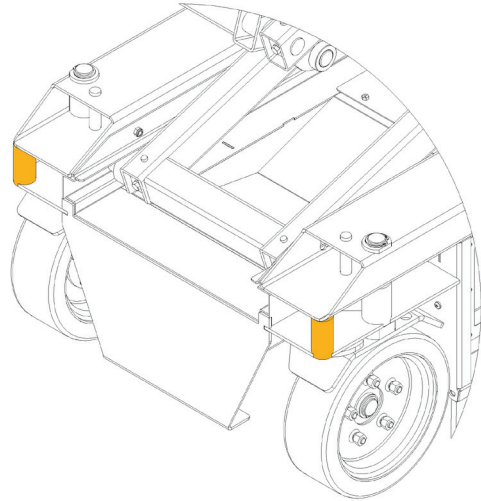

FIGURE 12: Tie-Down Points, Front

 **WARNING**

**DO NOT OVERLOAD BINDERS WHEN SECURING  
LOAD FOR TRANSPORT**

**5.5 | FORK LIFT POCKETS**

- Fork lift pockets are provided from the rear of the unit for loading and unloading.
- Forklifting from the side of the machine is not recommended.
- Do not use a forklift underneath the machine from the back.
- When moving machine with a forklift, do not let machine slide along floor. Bring forklift to a stop and then gently lower the machine.

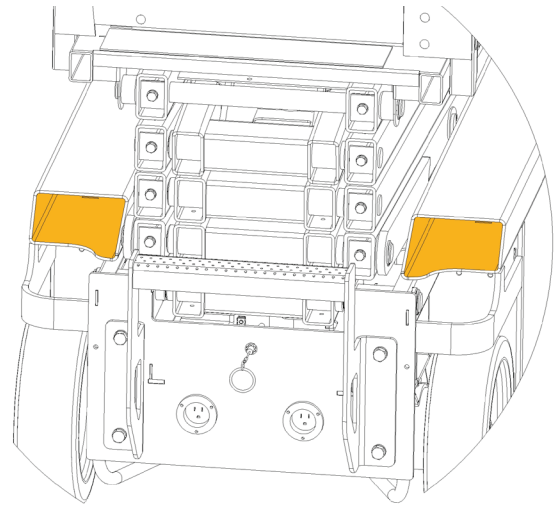

FIGURE 13: Fork Pockets

**5.6 | CENTER OF GRAVITY**

	<b>X Axis</b>	<b>Y Axis</b>
PS-1030	32.5 in (82.6 cm)	16.5 in (41.9 cm)
PS-1430	32.5 in (82.6 cm)	17.6 in (44.7 cm)
PS-1930	32.2 in (81.8 cm)	19.1 in (48.5 cm)

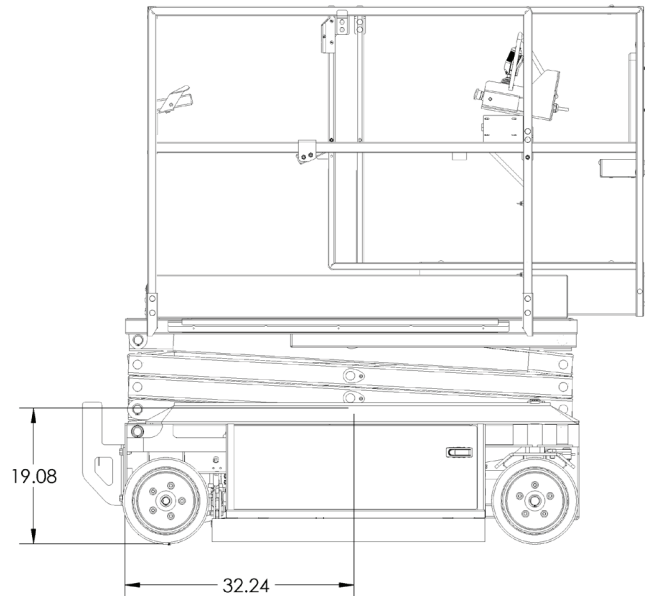

FIGURE 14: Center of Gravity

---

THIS PAGE WAS INTENTIONALLY LEFT BLANK

### 6.1 | BEFORE YOU OPERATE

Before use each day or at the beginning of each shift, the machine shall be given a visual inspection and functional test. Repairs (if any) must be made prior to operating the machine, as it is critical to ensure safe operation of the machine. A checklist for pre-start inspection can be found in the “Pre-start Inspection” section of this manual.

### 6.2 | BASE CONTROLS

Item	Control   Indicator
1	Up/Down Rocker Switch (Operation described in section 6.10)
2	Beeper (Tilt/Descent Alarm)
3	Emergency Stop (Operation described in section 2.5)
4	Master Power Key Switch (Operation described in section 6.7)
5	Overload Light (Operation described in section 2.4)

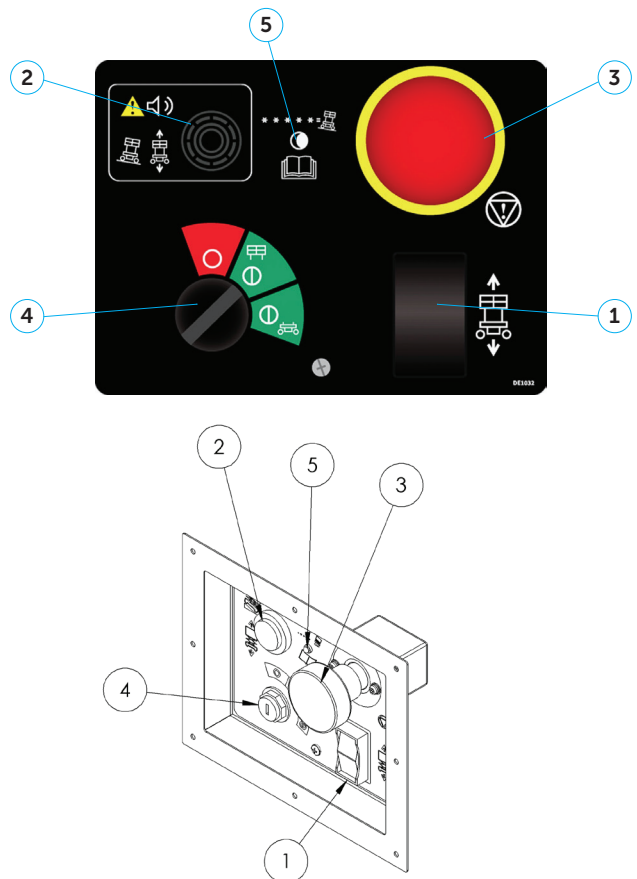

FIGURE 15: Base Controls

### 6.3 | BRAKE RELEASE

To release brake for winching or pushing

1. Ensure the unit is powered up and in the stowed position.
2. Select and maintain ground mode with the key switch on the lower control panel.
3. Press and hold the down function on the lower control panel until a solid tone from the alarm is heard (this should take approximately 5 seconds).
4. The brakes are released while the solid alarm is present.
5. To reengage the brakes, cycle the power off and on from any of the e-stops or the key switch.

Do not push at speeds more than 2 mph (0.9 m/s).

**NOTE:** The brakes will remain released when the key switch returns to platform controls. The drive system will not function if the parking brake is released.

**6.4 | PLATFORM CONTROLS**

Item	Control   Indicator
1	Emergency Stop (Operation described in section 2.5)
2	Drive Enable Trigger (Operation described in section 6.9)
3	Joystick (Operation described in section 6.4/6.5)
4	Steering Switch (Operation described in section 6.9)
5	Lift Mode Selector Button (Operation described in section 6.10)
6	Drive Mode Selector Button (Operation described in section 6.9)
7	Outdoor Configuration Button (Operation described in section 6.9)
8	Information Display (Operation described in section 6.5)
9	Indoor Configuration Button (Operation described in section 6.9)
10	Information Button (Operation described in section 6.5)
11	Horn

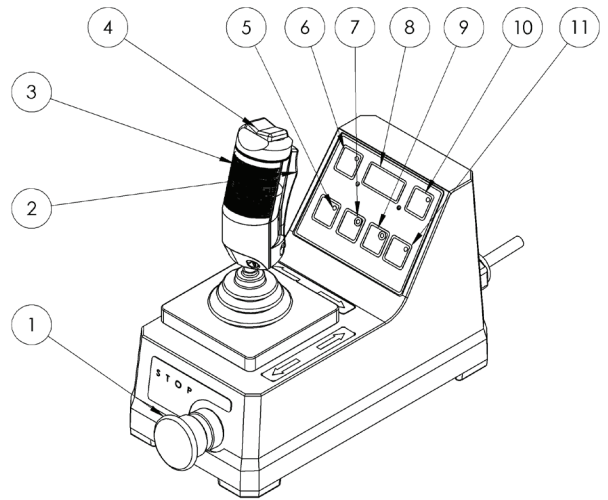
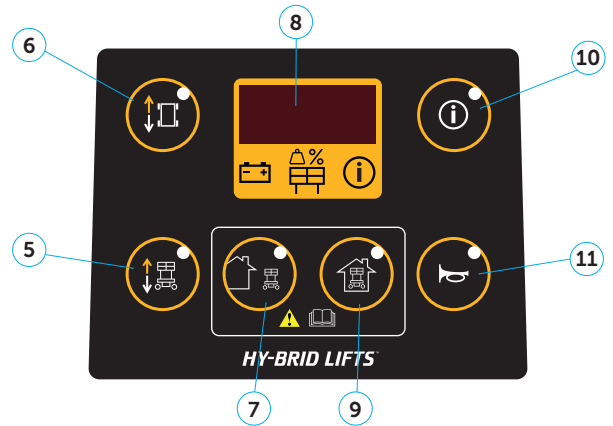

FIGURE 16: Platform Controls Style 1



FIGURE 17: Platform Controls Style 2

**6.5 | INFORMATION DISPLAY FEATURE**

The information button described in the platform controls section can be used to cycle through different lift characteristics on the information display.

**Battery: (N/A)**

The remaining battery life is shown through progressively disappearing bars.

**Height: OH**

OH is displayed when the lift reaches maximum height in outdoor mode.

**Hourmeter: H**

Alternating between displaying the "H" and the hours the machine has been used.

(ex: H, 04, H, 04 = machine has been used for 4 hours)

**Level: EL**

EL is displayed if the lift is tilted past manufacturer rating.

**Load: L**

The proceeding two digits will give the amount of rated load on the platform in the form of a percentage. This will display OL when the platform is overloaded.

(ex: L50 = Platform is carrying half of the rated load)

**BATTERY STATUS DISPLAY**

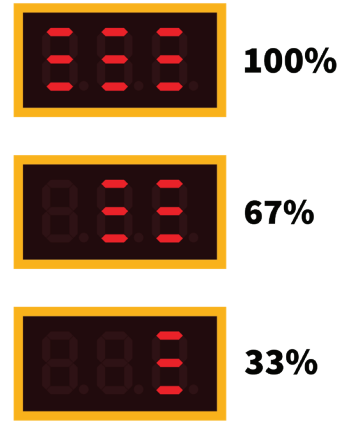

FIGURE 18: Battery Life Display

**6.6 | INFORMATION DISPLAY DIAGNOSTICS**

If there is a error on the machine a code will illuminate on the information display of the platform controls.



**PERFORMING UNAUTHORIZED MAINTENANCE  
COULD RESULT IN DAMAGE TO EQUIPMENT OR  
MAKE UNIT UNSAFE TO OPERATE. CONTACT THE  
OWNER OF THIS UNIT FOR TROUBLESHOOTING NOT  
COVERED IN THIS MANUAL**

Code	Action
2-2	A safety feature is locking functions or a switch has failed. Check that platform is not overloaded, operating on a level surface, and pothole guards deploy. Check that joystick is neutral when powered on. Check that joystick trigger is not closed for too long without selecting a function. If error persists, contact the owner of this equipment for maintenance.
4-4	Battery supply is too low or too high. Make sure batteries are fully charged. Do not operate while charging. If error persists, contact the owner of this equipment for maintenance.

**For all diagnostic codes not listed above contact the owner of this equipment for maintenance.**

**6.7 | STARTUP/SHUTDOWN** **WARNING**

**THE OPERATOR MUST BE AWARE OF THE ENVIRONMENT. DO NOT RAISE THE PLATFORM IF THE MACHINE IS NOT ON A FIRM, LEVEL SURFACE.**

**Operation Start-up and Shutdown Practices**

- Check that the work area is safe.
- Check that the Operation & Safety manual is inside the weatherproof box.
- Check that the emergency stops are pulled out.
- Ensure that the key in the lower control panel is in the "ON" position for the upper controls. The key may be continuously held in the lower control position to operate ground controls.
- Machine must be on a hard, level, surface before operation.
- Enter the work platform in the stowed position using the constant three point contact method.
- Follow all general rules and precautions stated in this manual.
- When finished with the machine, place the platform in the stowed position.
- Park the machine on a level surface.
- Carefully exit the platform using the constant three point contact method.
- NEVER JUMP OFF PLATFORM.
- Remove key from lower control panel to prevent unauthorized use.

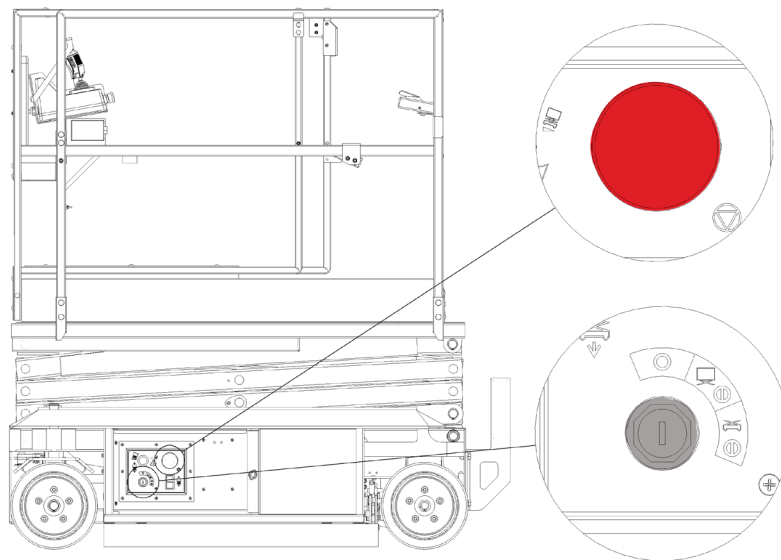

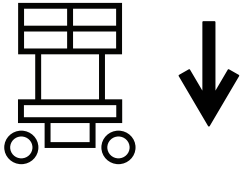

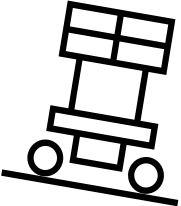



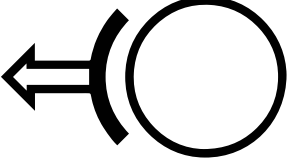

FIGURE 19: Master Power and Key Switch

**6.8 | ERROR ALARMS**

The table below lists audible alarms that signal a potential hazard or that an interlock is functioning.

 <b>Alarm</b>	<b>Alert Illustration</b>	<b>Meaning</b>
 Slow Pulse		Machine is descending. Be aware of bystanders and possible obstructions.
 Medium Pulse		Machine is on a slope. Lower the platform and move to a level surface before elevating.
 Fast Pulse		Machine Begins Elevating and Stops: Pothole Guards Not Engaged-Check for Obstruction
 Solid		Machine will not drive: Brakes are released. Cycle power off and on before use. OR Battery charger is plugged in. Unplug before use.

**6.9 | DRIVING AND STEERING** **WARNING**

**CHECK THAT THE ROUTE OF TRAVEL TO BE TAKEN IS CLEAR OF PEOPLE, OBSTRUCTIONS, DEBRIS, HOLES, AND DROP-OFFS; AND IS CAPABLE OF SUPPORTING THE MACHINE.**

 **WARNING**

**USING THE INDOOR SETTING FOR OPERATING OUTDOORS (WIND IS PRESENT) CREATES A TIP HAZARD**

Always check front steer wheel direction before driving.

This unit is equipped with an indoor/outdoor use selection function. Outdoor use is defined by the presence of wind.

Never operate lift on wet/frozen surfaces.

For best control, distribute the load on the work platform starting from the rear of the machine if possible.

To activate drive function, select drive mode using the button on the platform control box.

To drive, hold the joystick trigger while moving the joystick. Moving the joystick will cause the machine to drive in that direction. Moving the joystick handle away from the operator will cause FORWARD travel, and pulling the joystick toward the operator will cause REVERSE travel. Use the rocker switch on the top of the joystick to adjust the wheels. Holding the switch to the left will adjust the front wheels to turn LEFT. Holding the switch to the right will adjust the front wheels to turn RIGHT. Travel speed is proportional and is controlled by the joystick. The farther it is moved, the faster the speed will be. The joystick returns to the neutral position when released.

**BRAKING:** For parking, the brake is automatically applied when the joystick is positioned in the center (neutral) position.

## 6.10 | ELEVATING AND LOWERING

### Using Upper Platform Controls

The key switch on the base controls defaults to the platform controls in the "ON" position.

Ensure the proper configuration (indoor/outdoor) is selected on the upper controls.

To activate elevate/lower function, select elevate mode using the button on the platform control box.

To elevate/lower, hold the joystick trigger while moving the joystick. Moving the joystick handle away from the operator will cause lowering, and pulling the joystick toward the operator will cause elevating. Elevating speed is proportional and is controlled by the joystick. The farther it is moved, the faster the speed will be. The joystick returns to the neutral position when released.

### Using Base Controls

Hold the key switch to select the base controls. Pressing the top of the rocker switch raises the platform, pressing the bottom lowers the platform.

## 6.11 | EXTENDING THE PLATFORM

1. Stand on the platform deck.
2. Grip the slide lock handle and push down, allowing the deck to slide.
3. Slide the deck out to a locking point, fully extended at approximately 30 in (76 cm), at a midway locking point, or fully retracted.
4. Release the handle to keep deck in place. Be sure lock is engaged before entering.

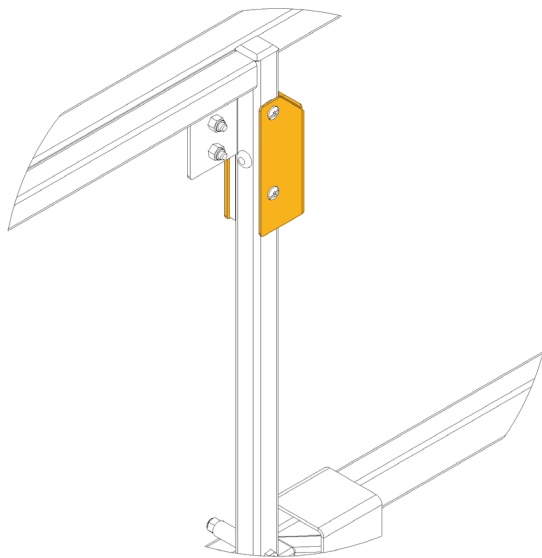

FIGURE 20: Slide Lock Handle

### **WARNING**

**DO NOT DRIVE UNIT WHEN STANDING ON EXTENSION. STAND ON PLATFORM BEHIND JOYSTICK.**

### **WARNING**

**IF THE SLIDE-OUT DECK IS EXTENDED, RETRACT THE SLIDE-OUT DECK, OR CHECK FOR CLEARANCE UNDER AREA BEFORE LOWERING PLATFORM.**

## 6.12 | POWER TO PLATFORM

This unit is equipped with power to platform. Power to platform provides the operator with a 110V AC power supply to the platform.

### To Use Power to Platform

1. Attach the power to platform plug securely to an external power supply.
2. Plug electronic tools and equipment into the power to platform outlet located under the platform controls.

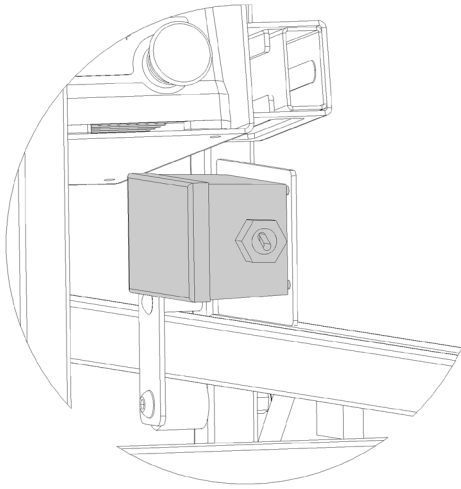

FIGURE 22: Power to Platform Outlet

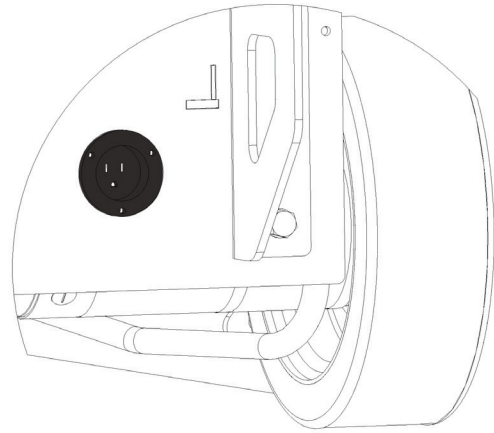

FIGURE 21: Power to Platform Plug

### 6.13 | DAILY MAINTENANCE

Regular inspection and conscientious maintenance is important to efficient economical operation of this machine. It will help to assure that equipment will perform satisfactorily with a minimum of service and repair. Make checks at the stated intervals or more frequently if required by local operating conditions. A Pre-Start Inspection Checklist is included in this manual.

Additional maintenance for use by trained personnel is included in a separate Maintenance Manual. Refer to the Maintenance Manual for Pre-Delivery/Frequent and Monthly Checklists and replacement part information.

## CAUTION

**FAILURE TO PERFORM INSPECTIONS AND PREVENTATIVE MAINTENANCE AT RECOMMENDED INTERVALS MAY RESULT IN THE UNIT BEING OPERATED WITH DEFECTS THAT MAY RESULT IN INJURY OR DEATH OF THE OPERATOR.**

### 6.14 | CHARGING THE BATTERY

This unit is equipped with deep cycle 12-volt batteries. The care and maintenance of your battery has much to do with how well this unit functions. Battery wiring and water level should be checked monthly. Do not overfill. When the cells are too full, fluid will seep out when charging.

**NOTE:** The surrounding temperature greatly affects the power reserve within a battery.

**EXAMPLE:** A battery that is 100% charged at 80° F (27°C) drops to 65% at 32°F (0°C). At 0°F (-18°C), this battery will drop to 40% efficiency.

The charger may include an interlock circuit. If so equipped, the unit will not operate while charging. Operating while charging can shorten battery life.

#### To Charge

- Park the machine on a level surface.
- Plug charger into AC outlet until charged.
- For best battery life, leave the charger plugged in until machine will be used again. The charger will maintain the battery charge.

## WARNING

**BATTERIES GENERATE EXPLOSIVE GASES. KEEP SPARKS AND FLAME AWAY FROM BATTERIES. DO NOT SMOKE WHILE CHARGING.**

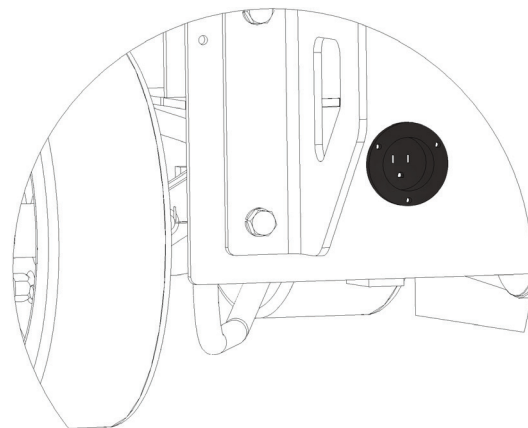

FIGURE 23: Charger Cord Location

6.15 | BATTERY DISPLAYS

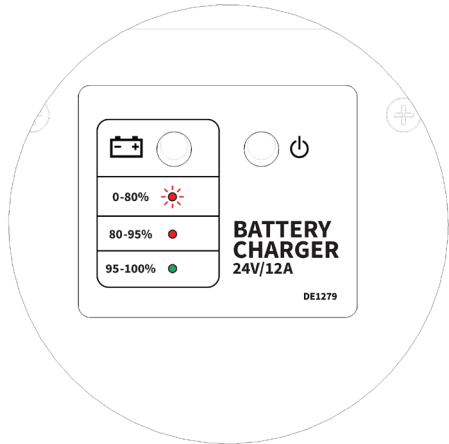

FIGURE 24: Battery Charger LED Display

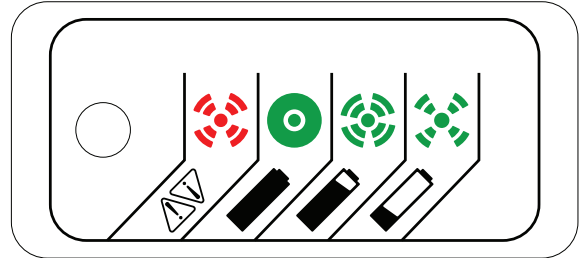

FIGURE 25: Battery Charge Display: Delta-Q RQ 350











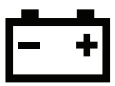

**CAUTION**

OPERATING WHILE CHARGING CAN SHORTEN BATTERY LIFE.

**CAUTION**

NEVER ADD ACID TO BATTERY!

Battery Charge Display: Pro Charging Systems IS2412

		MEANING
 (OFF)	 (SOLID)	<b>Standby Mode</b> (Or battery/ connection error)
 (FLASHING)	 (SOLID)	<b>Normal Charging</b> Bulk Charging
 (SOLID)	 (SOLID)	<b>Normal Charging</b> Absorption Stage
 (SOLID)	 (SOLID)	<b>Charge Complete</b> Flat/Maintenance Mode
 (FLASHING)	 (FLASHING)	<b>Charger Error</b>

**7.1 | PRE-START INSPECTION CHECKLIST**

Pre-Start Inspection (Pro Series)

Model: \_\_\_\_\_

Serial No. \_\_\_\_\_

- Keep inspection records up-to-date.
- Record and report all discrepancies to your supervisor.
- A dirty machine cannot be properly inspected.



**THIS CHECKLIST MUST BE USED AT THE BEGINNING OF EACH SHIFT OR AFTER EVERY SIX TO EIGHT HOURS OF USE. FAILURE TO DO SO COULD AFFECT THE SAFETY OF THE OPERATOR.**

**7.2 | LEAKGUARD™ FLUID CONTAINMENT SYSTEM**

If this unit is equipped with the LeakGuard™ Fluid Containment System, routine inspection should take place. Take off the pump side cover of the MEWP, and check the LeakGuard™ tray/pad for hydraulic fluid. While conducting inspection, be certain to wear gloves and other PPE as necessary. If the pad must be replaced, contact the owner for maintenance.

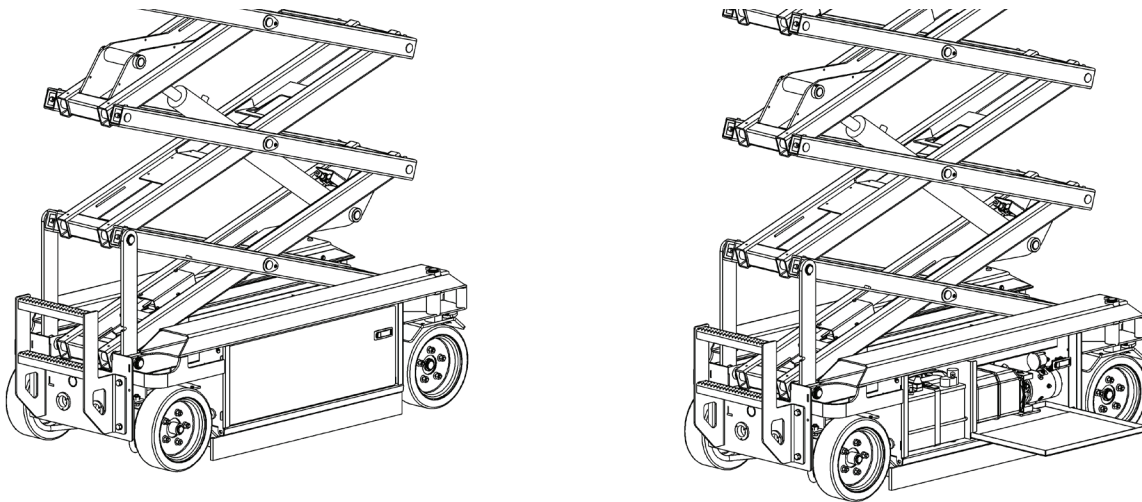

FIGURE 26: LeakGuard™ Location

**PRE-START INSPECTION CHECKLIST**

(Print this page for additional inspections)

<b>Y-Yes/Acceptable N-No/Unacceptable R-Repaired N/A-Not Equipped</b>	<b>Y</b>	<b>N</b>	<b>R</b>	<b>N/A</b>
<b>VISUAL INSPECTIONS</b>				
There are no loose or missing parts.				
Check that warning and instructional labels are legible and secure. Ensure that load capacity is clearly marked.				
Check the platform rails and safety gate for damage.				
Platform and base controls are not missing, damaged, or disconnected.				
Electrical cables and wires are not torn, frayed, or disconnected.				
Hydraulic hoses are not torn or loose, and there are no leaks. Hoses and the cables have no worn areas or chafing.				
If machine is equipped with LeakGuard™ check tray for hydraulic fluid				
Check the tires for damage.				
Check that all snap rings are secure in grooves on pivot pins.				
<b>FUNCTIONAL TESTS</b>				
Gate closes automatically and latches.				
Platform Controls: Check all switches and push buttons for proper operation.				
Emergency Stop (Stops all movement)				
Drive Mode Button (Selects drive/steer mode)				
Up/Down Button (Selects elevate mode)				
Joystick: (Return to neutral, drives forward & reverse.) Enable Trigger (Must be activated for joystick-operated movement) Rocker Switch (Moves front wheels left and right) Elevates & lowers				
Horn sounds when button is pressed.				
Information button cycles through battery life (percent), load capacity (percent), and hour meter (hours) when pressed.				
Base Controls: Check all switches and push buttons for proper operation.				
Emergency Stop (Stops all movement/Disconnects battery)				
Key Switch/Master Power Switch (Selects Platform Control, Ground Control, or Off )				
Up/Down Rocker Switch (Elevates, Lowers)				
Descent Alarm (Not damaged, sounds for descent; may also sound for drive & elevate, if so equipped)				
Tilt Alarm (Not damaged, sounds when tilted and machine elevated above designated height)				
Wheels: Front and rear wheels rotate freely.				
Drives in slow speed when elevated.				
Brakes: Machine stops when joystick released.				
Pothole guards deploy and lock when platform is elevated.				
Lift does not elevate when pothole guards are blocked.				
DATE:	INSPECTED BY:			





# **HY-BRID LIFTS™**

BY CUSTOM EQUIPMENT LLC

Self-Propelled  
Mobile Elevated Work Platform  
PS-1030, PS-1430, PS-1930

Operation & Safety  
Manual

Custom Equipment, LLC  
2647 Highway 175  
Richfield, WI 53076  
U.S.A.

 [+1.262.644.1300](tel:+12626441300)

 [+1.262.644.1320](tel:+12626441320)

 [axcs.com](http://axcs.com)

“Hy-Brid Lifts” is a trademark of Custom Equipment, LLC. These machines comply with ANSI/SIA A92.20, CSA B354.6:17, and EN-280:2013+A1:2015.

Revision Date: March 2023

Printed in the U.S.A.